

## *Sanitary*

dry-disconnect  
couplings for the  
Pharmaceutical and  
Biotech Markets

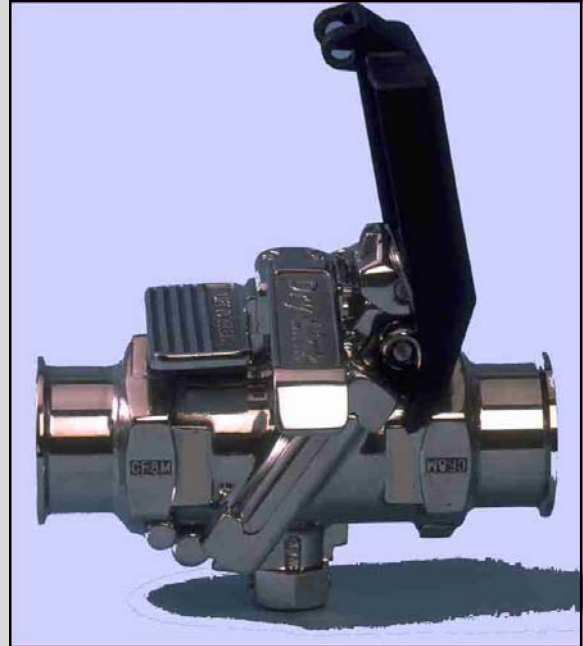

**Stainless Steel 316  
and  
Hastelloy C materials**



# Solutions Providers to the Pharmaceutical & Biotech Markets



Whether you are a small-scale lab, medium sized batch processor, or large manufacturer, we offer the right dry-disconnect coupling to suit your needs – with full support and validation from start to finish.

**Beware!** There are many so called “sanitary” dry-disconnect (dry-break) couplings on the market today. But most of them have *unpolished* internal finish that is unacceptable in sanitary applications. These couplings are usually based on poppet valve or ball valve designs. By nature, these couplings are not sanitary because they can trap liquid and allow bacteria to germinate. A poppet valve will always contain a dead volume of liquid, no matter what, and a ball valve design allows a dead space between the ball and the body.

In the ball valve design, some manufacturers have attempted to *eliminate* the dead space by inserting plastic shims (PTFE fillers) around the ball. The problem with fillers is that you cannot be 100% sure if you have completely *filled* in the dead space. It would be impossible to determine the exact thickness required for the filler because of variations in the cast body and ball dimensions. If you assemble the body using a slightly thicker filler, the coupling will jam and make it impossible to turn the handle. If the filler is slightly thinner, then certainly there would be a small void around the ball – enough for the liquid to seep into the void and create a dead volume for bacteria to germinate.

Dry Link sanitary polished couplings in sizes 1/2" through 4" are the only true sanitary, drip-free couplings available today because of their simple butterfly design. The smooth mirror-polished bore has no voids, dead spaces, crevices, or fillers that could trap bacteria. Easily drainable and sanitized using steam or other methods such as CIP, SIP, etc., our sanitary couplings are routinely specified in pharmaceutical, biotech, semiconductor, food, and cosmetic industries where ultra cleanliness is required.

Dry Link sanitary couplings are usually specified with wetted internal components *polished* to 20 RA micro-inch mirror finish, although we also offer unpolished internals at economy prices. Wide choice of sizes, body & seal materials, end connections and with full material test certifications (MTR), FDA & USP certifications are available. Other options such as extra fine inside polish, and outside polish to matte finish. We also offer *keyed* sanitary couplings for preventing accidental cross-contamination of fluids. Please see details in our comprehensive Product Catalog or visit us at [www.drylink.com](http://www.drylink.com) for a video demonstration of our couplings in action!